



# SHARP TOP CHAINS and accessories

# Sawmill chains

## Products for sawmills and the wood handling industry

Unique experience  
Wide range

Our special chains for the timber, paper and pulp industries have what you can expect – superior quality, large range of models and short lead times. Our products are tried and tested to live up to the various stresses and strains that may arise.

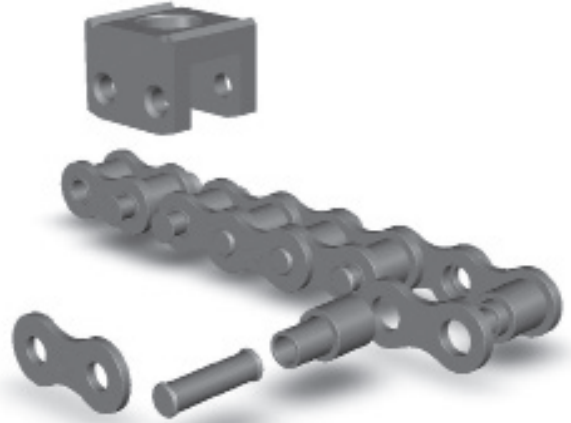

### SBR Sawmill chain (Sharp top chain)

The SBR technology – solid bushes and rollers – significantly reduces the chain elongation in comparison with standard chain. This superior quality offers you as user reduced plant downtime and unforeseen production stoppages, faster processing and minimized maintenance.



### Sorting chain

Timber sorting is the heart of the production process; without a reliable chain in your production line the process will not work. That is why we have developed a chain that will last.

Our chain has been developed alongside our customers over many years and in cooperation with engineers, industry experts and heat treatment specialist. The design has been adapted to achieve an optimized combination of materials, manufacturing methods, dimensions and assembly methods. This has resulted in a chain that today is distributed all over the world.

We also supply accessories for your timber sorting, sprocket and chain for your drive unit.

# Your total supplier of chain products

## Information

## We provide you with the equipment you need, from the smallest chain to the largest

Allow our knowledgeable staff to help you streamline your day to day work! Arrange a visit from one of our technical salespeople, who will come to your premises in order to assess the status of your facilities. We document your chains as well as peripheral equipment, and propose optimal solutions aimed to minimize unforeseen, costly production stoppages. FB Chain only works with high quality products, guaranteeing a long service life and safe operation.

To ensure we do not leave any important details to chance, we naturally install and carry out follow up inspections of our products. We offer continual training in the field of chain and accessories in Eskilstuna, as well as at our own conveyor chain factory FB Ketjutekniikka Oy in Köyliö, Finland.

*“You book a visit – We supply a total solution!”*

## Service and advice

Optimization  
Documentation  
Installation

We do not only provide products. As one of the largest suppliers of total solutions and chain renovations we possess a unique expertise – and we are happy to share it! We extend the service life and minimize costs for maintenance of your transmission systems. We also offer training at our premises in Eskilstuna as well as at our conveyor chain factory and subsidiary FB Ketjutekniikka Oy in Köyliö, Finland.

## Montage och service

Mechanical maintenance  
Service agreement

Besides quality chain products and consulting, we also offer installation and service of components. Secure your operation and let our experienced staff take care of installation, service and maintenance in a safe and efficient way.

## Operations

FB Chain only works with high quality products, guaranteeing long service life and a safe operation. To ensure the quality, we also install and follow up with inspections of our products. We provide in house produced products supplemented with products from some of the best manufacturers in the sector. Our workshop premises in Eskilstuna give us flexibility in dealing with our customers.



# Sharp top chains 1" (16B)

European standard

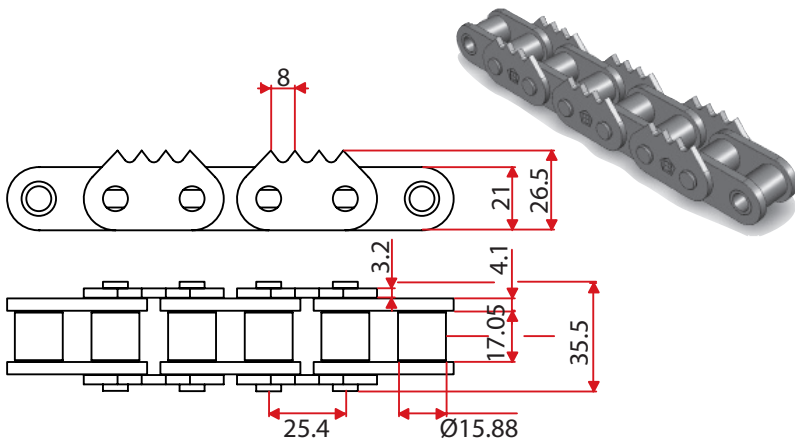

5118.000.34

Sharp top chain 16B-1

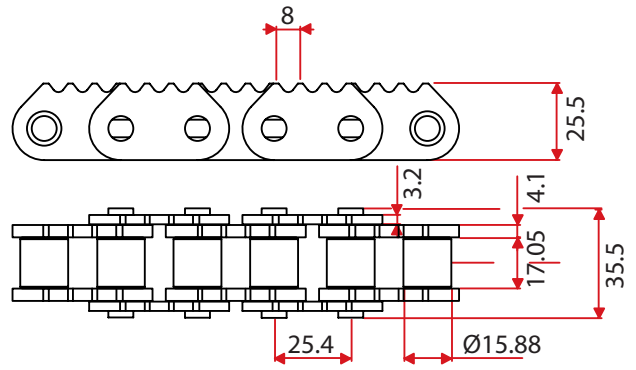

5118.000.35

Sharp top chain 16B-1

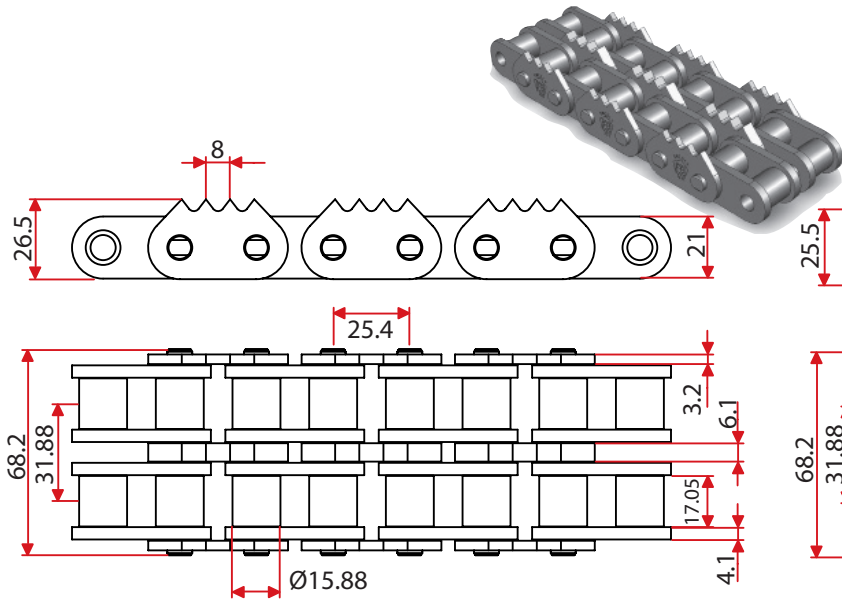

5218.000.18

Sharp top chain 16B-2

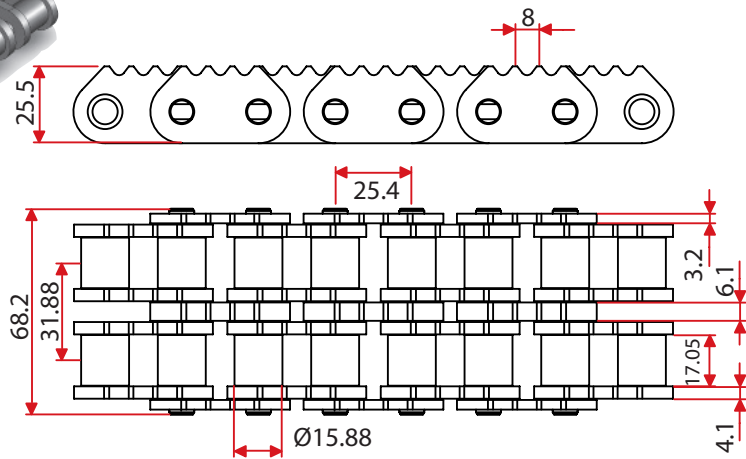

5218.000.19

Sharp top chain 16B-2

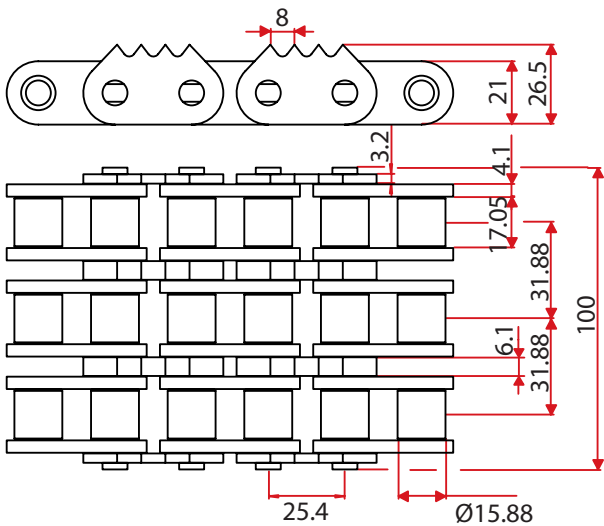

5318.000.06

Sharp top chain 16B-3

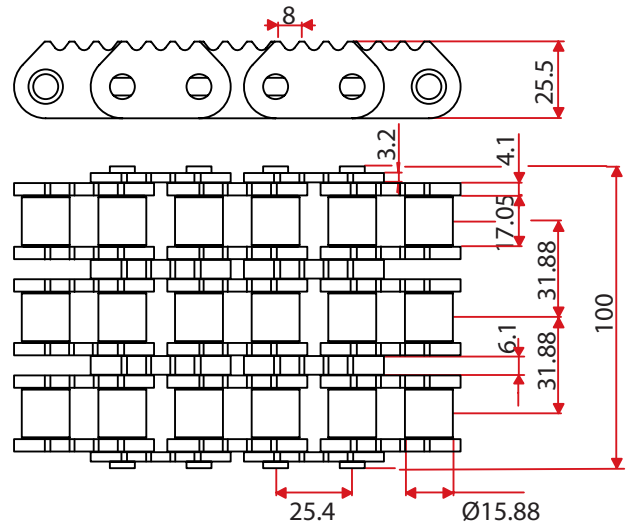

5318.000.07

Sharp top chain 16B-3

# Sharp top chains 1" (16B)

European standard

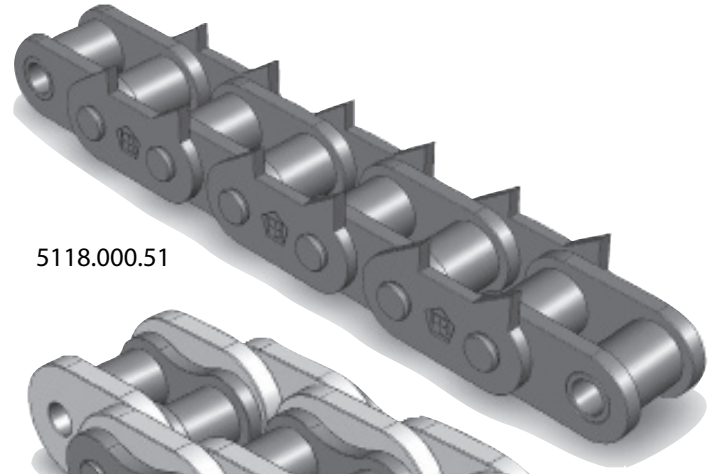
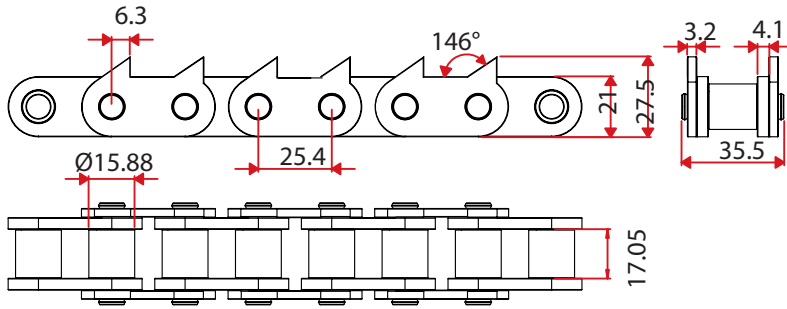

5118.000.51

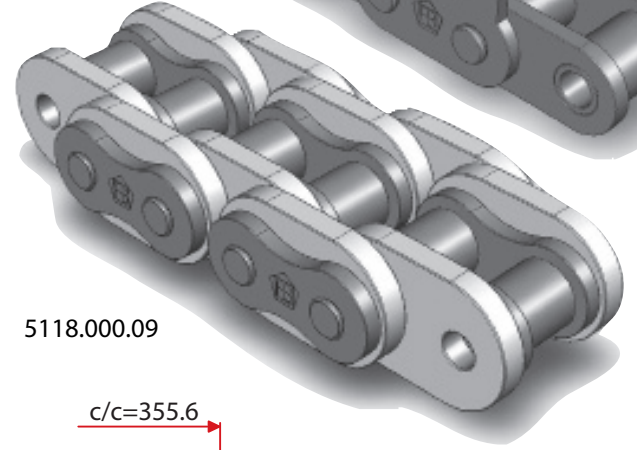

5118.000.09

5118.000.51  
Sharp top chain 16B-1

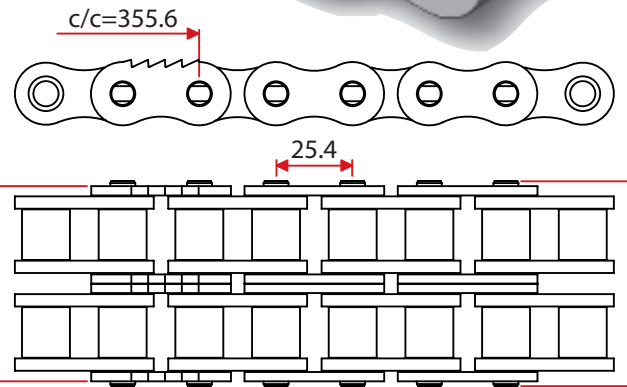
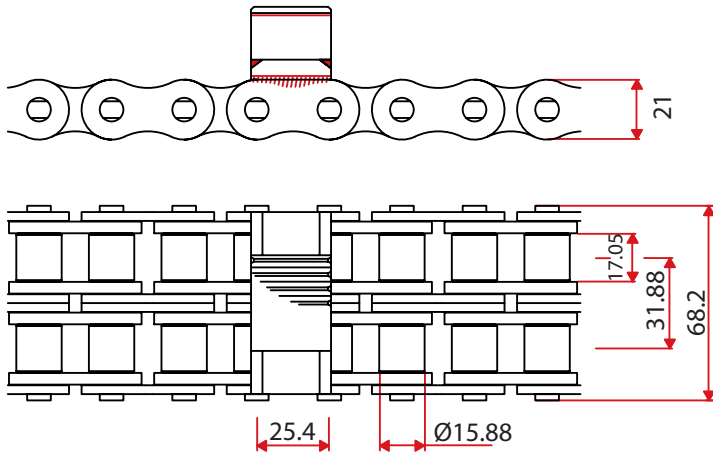

5218.000.10  
Sharp top chain 16B-2

5218.000.20  
Sharp top chain 16B-2

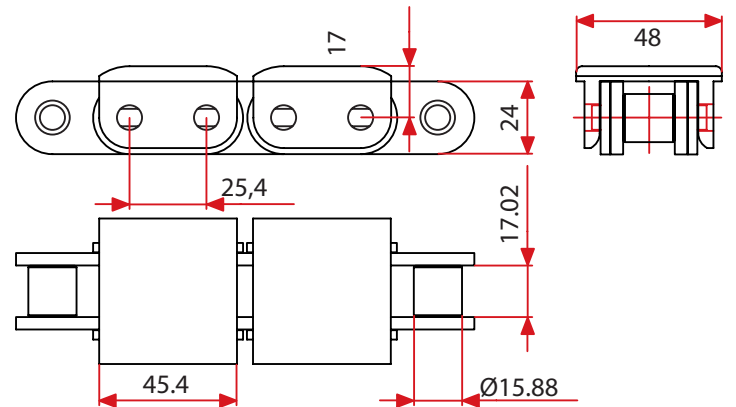
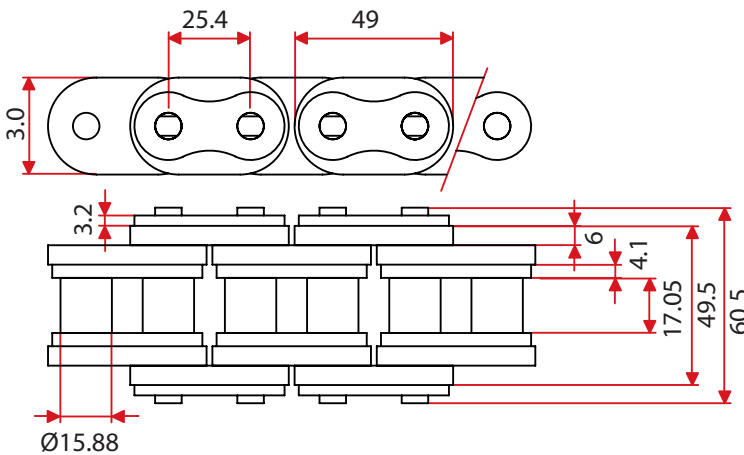

5118.000.09  
Sharp top chain 16B-1

5212.000.08  
Sharp top chain with plastic cover. 16B-1



# Sharp top chains 1 1/4" (20B)

European standard

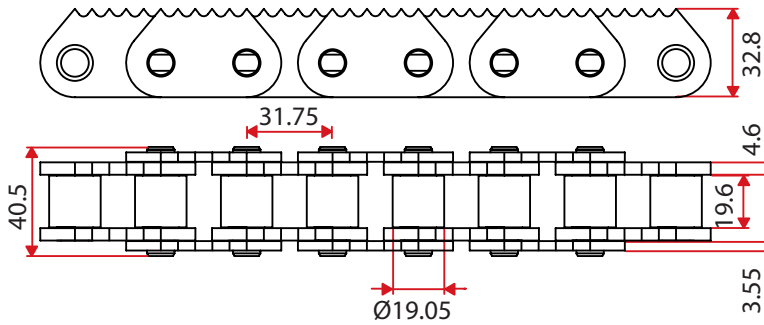

5130.000.22

Sharp top chain 20B-1

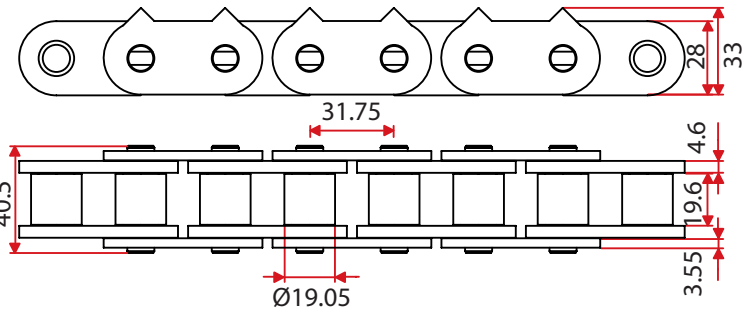

9035.000.3

Sharp top chain 20B-1

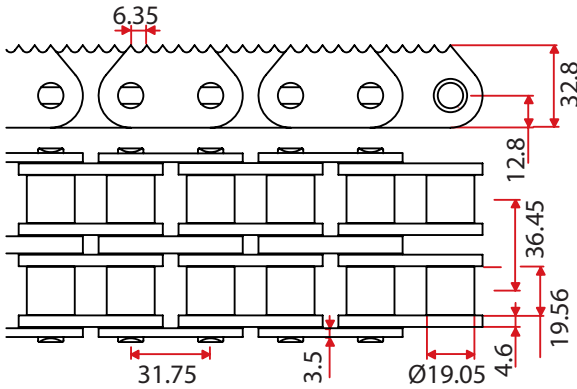

5230.000.03

Sharp top chain 20B-2

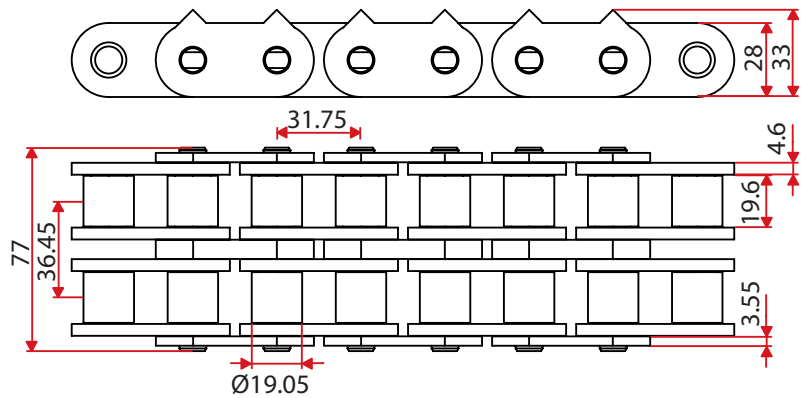

5230.000.04

Sharp top chain 20B-2

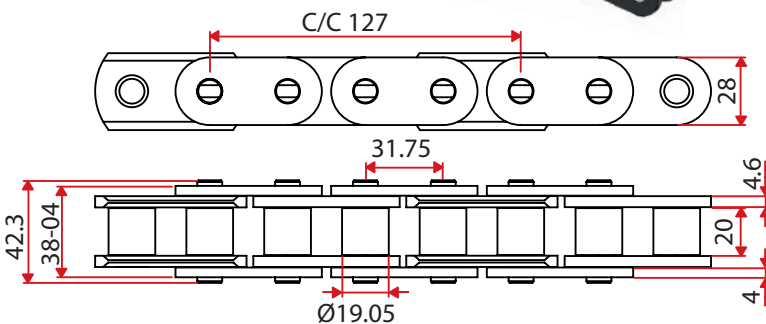

5130.000.05

Sharp top chain 20B-1

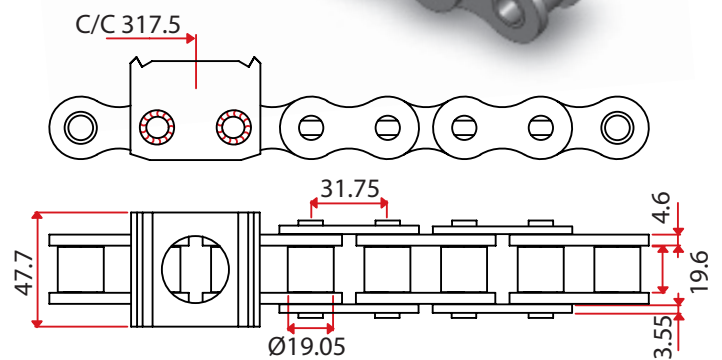
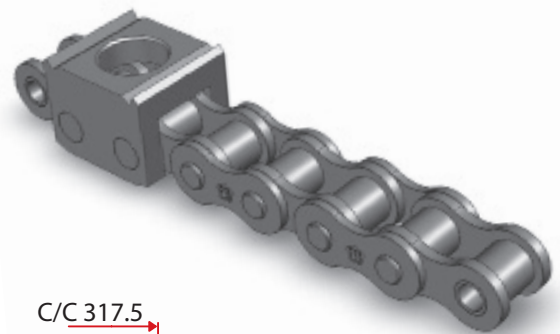

5130.000.44

Sharp top chain 20B-1

# Sharp top chains 1 1/2" (24B)

European standard

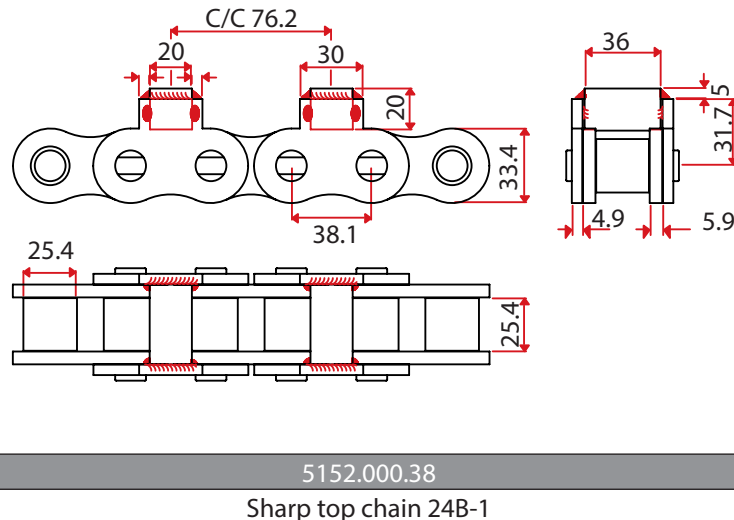
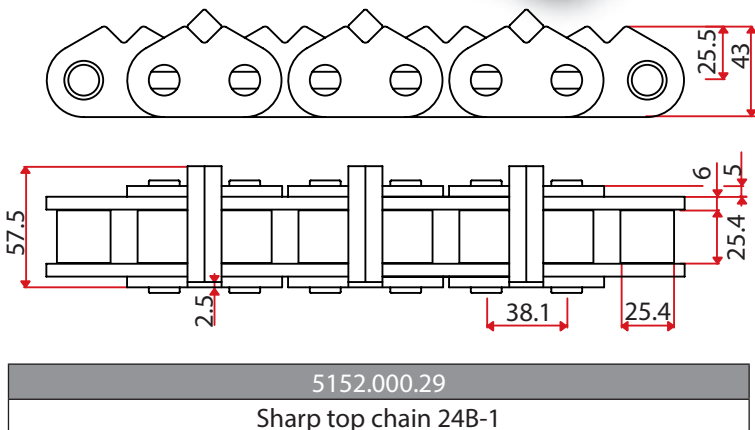
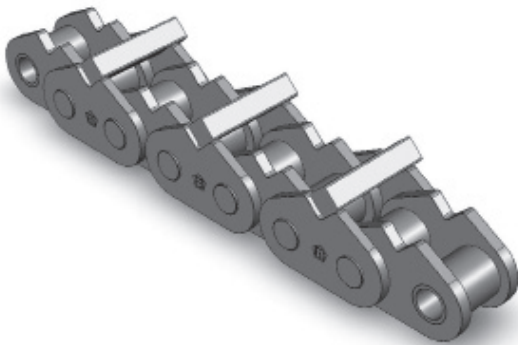
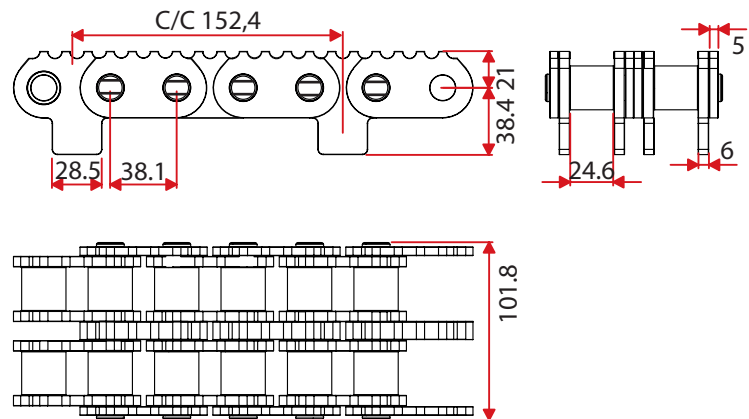
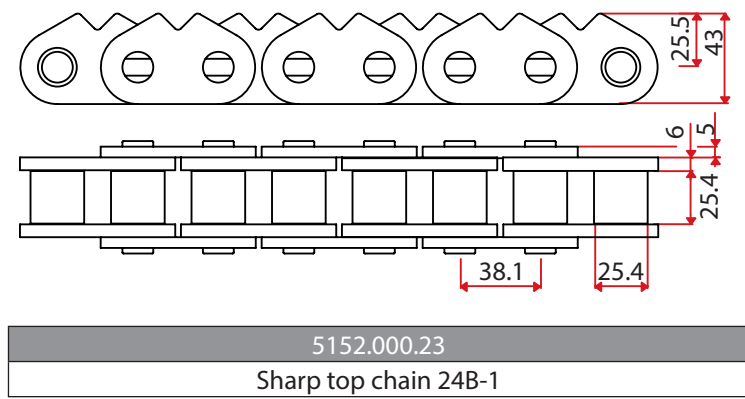
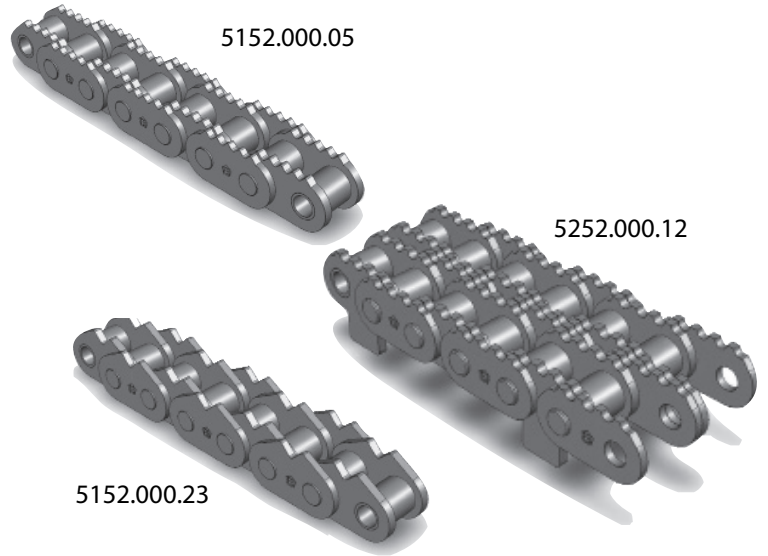
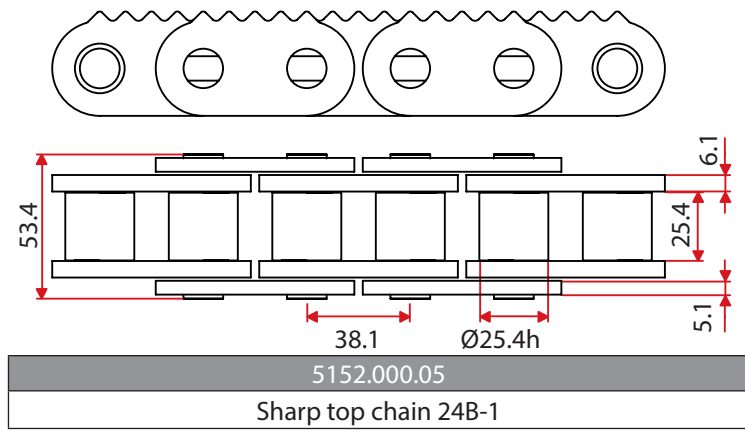

# Sharp top chains 2" (32B)

European standard

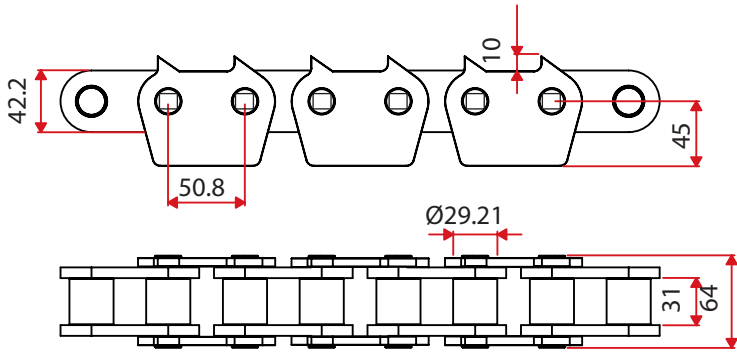

5269.000.4

Sharp top chain 32B-1

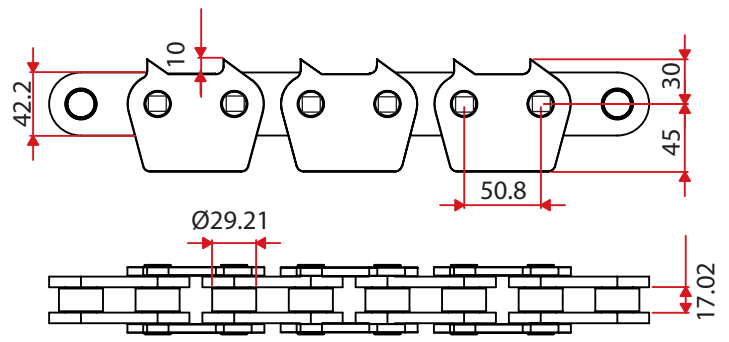

5202.000.8

Sharp top chain 32B-1

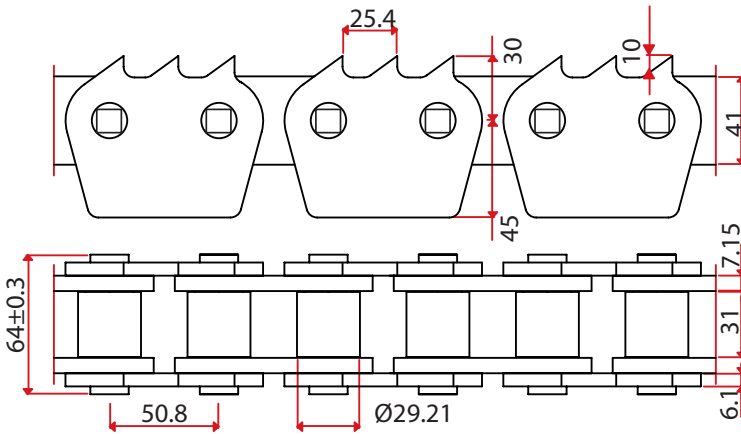

5167.000.12

Sharp top chain 32B-1

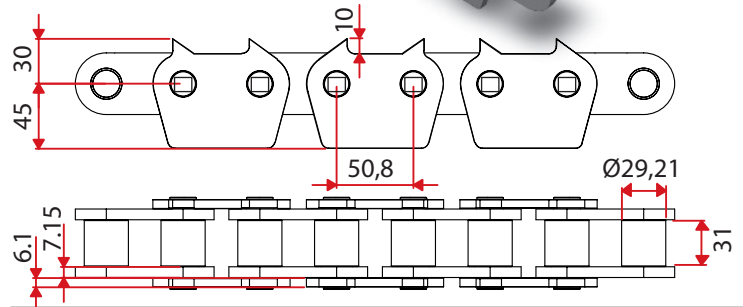
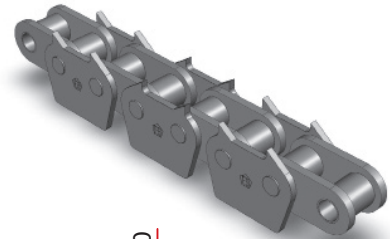

5167.000.08

Sharp top chain 32B-1

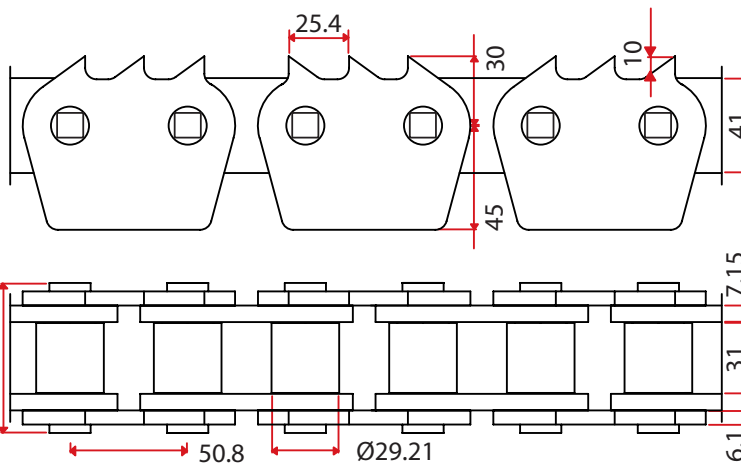

5167.000.20

Sharp top chain 32B-1

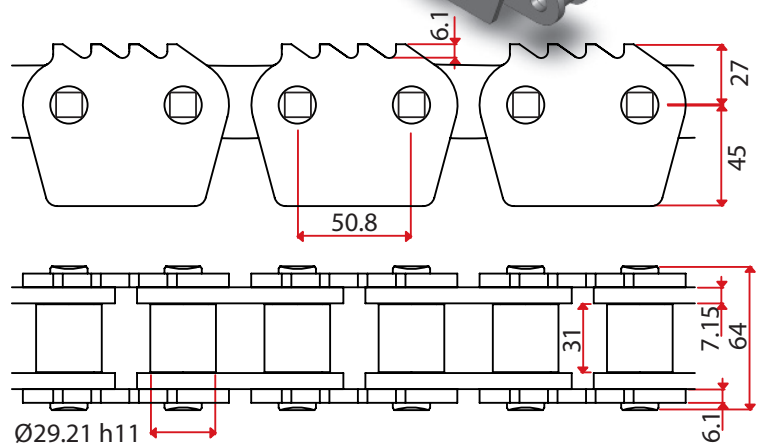
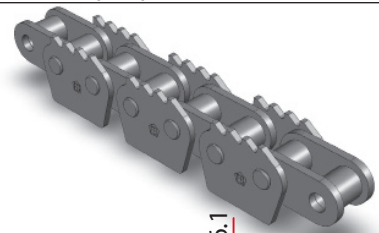

5167.000.45

Sharp top chain 32B-1



# Sharp top chains 2" (32B)

European standard

5167.000.35

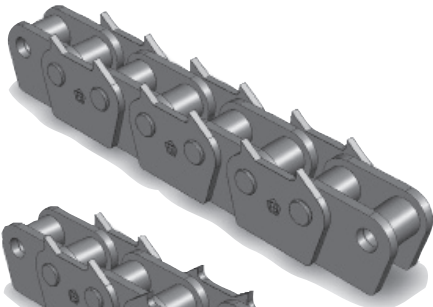

5167.000.44

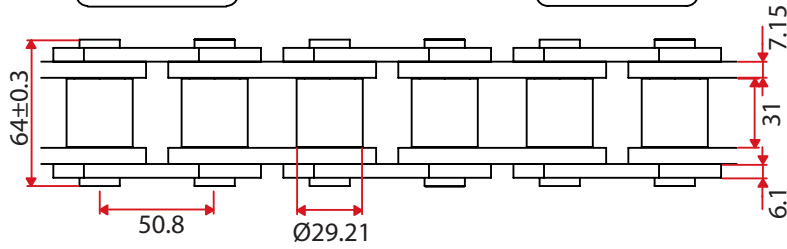
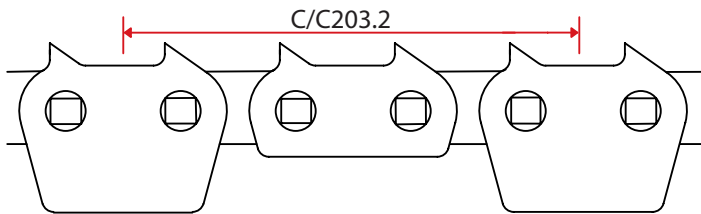
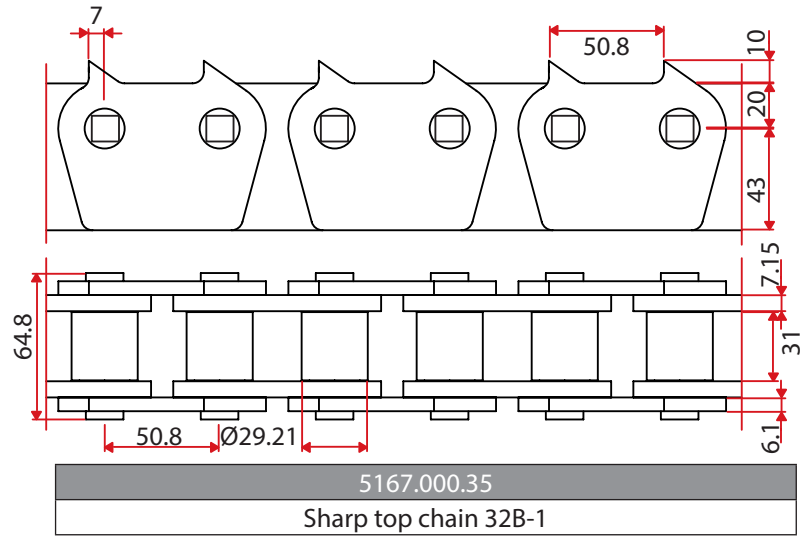
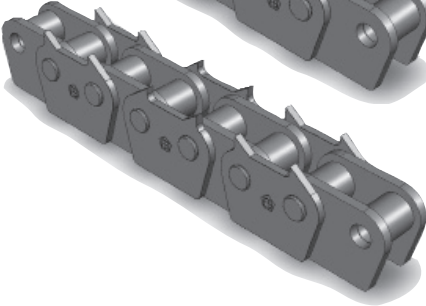

5167.000.38  
Sharp top chain 32B-1

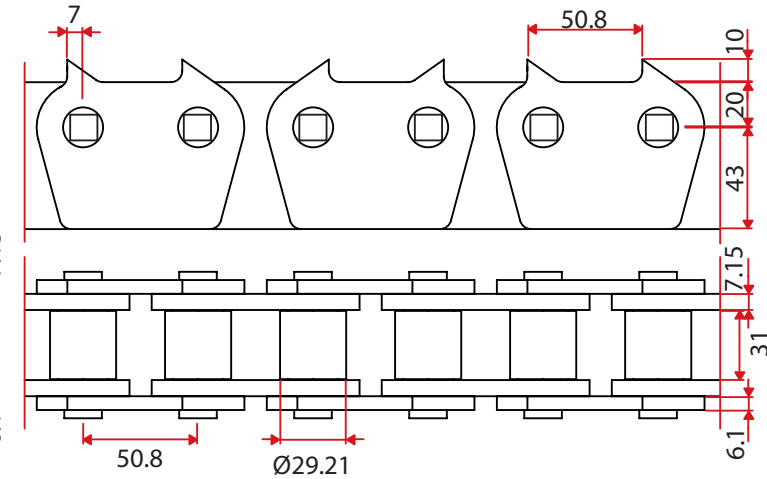

5167.000.44  
Sharp top chain 32B-1

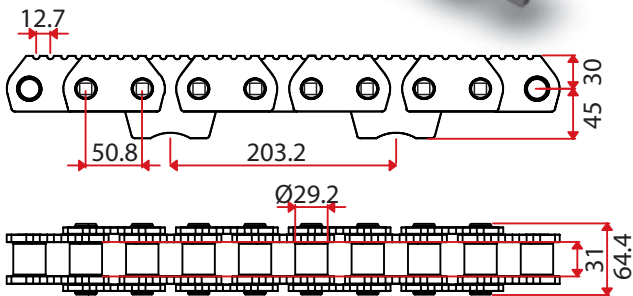
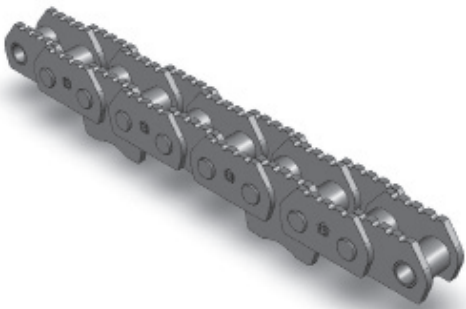

5167.000.56  
Sharp top chain 32B-1

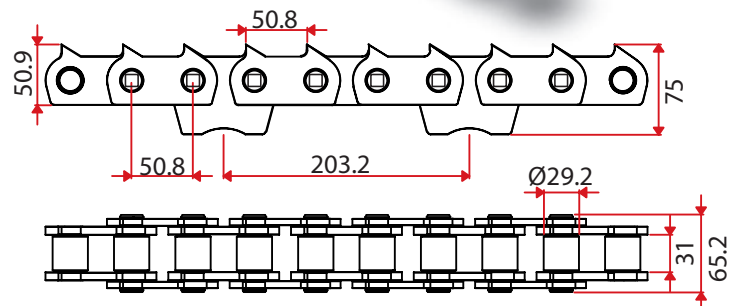
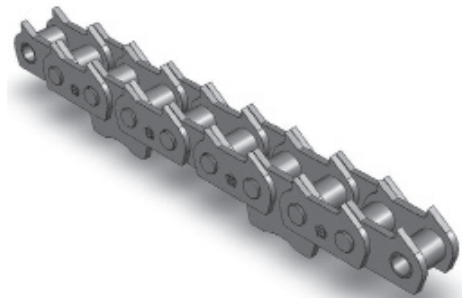

5167.000.55  
Sharp top chain 32B-1

## FB Kedjor in Europe

FB Kedjor AB, Sweden

FB Chain Ltd, Great Britain

FB Ketjutekniikka OY, Finland

FB Ketten GmbH, Austria

FB Ketten GmbH, Germany

FB Kjeder AS, Norway

FB Chaines Sarl, France

